

Teacher Word Study

Week of _____



My Name: _____

Your Words

Pick 1 to do:

- page 1
- pages 2-3

Spelling Break

Pick 1 to do:

- page 9
- page 10

Spelling Workout

Pick 4 to do:

- page 4
- page 5
- page 6
- page 7
- page 8



Name: _____

edHelper

Picture Dictionary

Draw a picture of 11 of your words. Write the word in cursive.



EXAMPLE. laughed

1. _____

2. _____

3. _____

4. _____

5. _____

Name: _____

edHelper

6. _____

7. _____

8. _____

9. _____

10. _____

11. _____

Name: _____

APPRECIATE • GRATITUDE • CONFIDENCE • LOGIC • EVALUATION
CONFERENCE

Write each word into the puzzle.

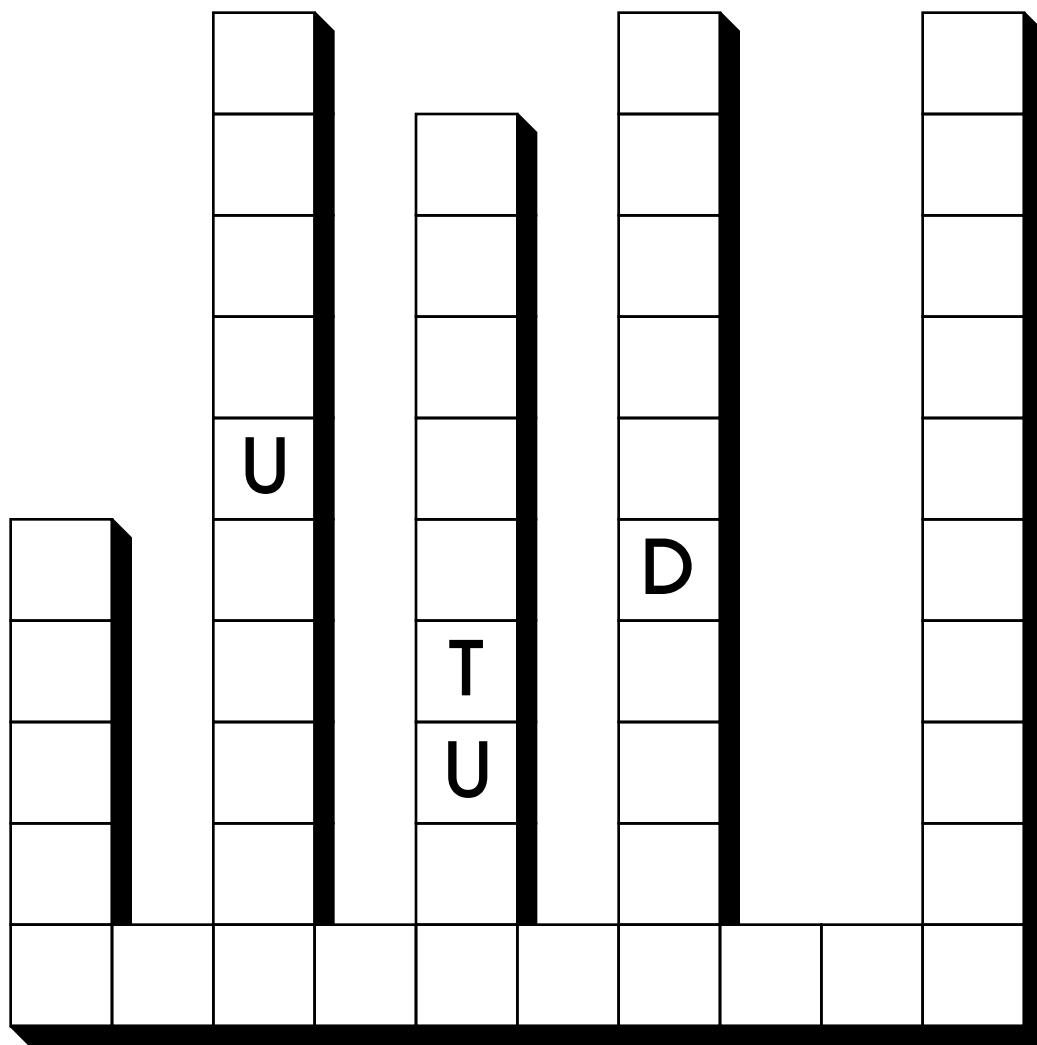

Circle the digit in the hundredths place.

682.44

16 kg = _____ g

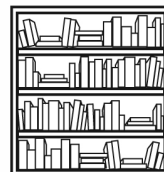

Name: _____

Circle words to the RIGHT or DOWN. Every letter is used exactly ONCE.

P G A T E S C R Y I N S P I R I N G
 R O V E R J E X P E C T A T I O N S
 E P E T S U T E N C O U R A G I N G
 S T L S E L C O N F E R E N C E
 S T E F I T E O E V A L U A T I O N
 U O N R C I T G B R A I N S T O R M
 R E D Y K F H I G R A T I T U D E
 E B A N D Y E C C U R R I C U L U M

Write the words found:

<u>CURRICULUM</u>	<u>GRATITUDE</u>	_____
_____	_____	_____
_____	_____	_____
_____	_____	_____
_____	_____	_____
_____	_____	_____

<p>The circus is in town! Tickets are only \$5 for kids. Adults need to pay double the price of kids tickets. Sara is bringing three of her friends in her class. Her mom is also coming. Sara wants to pay for everyone. How much will she need to pay?</p>	$15 \div 5 =$	$\begin{array}{r} 363 \\ + 256 \\ \hline \end{array}$
$(8 + 9) + 3 =$	$\begin{array}{r} 25 \\ + 35 \\ \hline \end{array}$	<p>Write whether this fragment is missing a subject or a verb. had a lot of fun _____</p>
<p>How many inches are in 5 feet? _____ inches</p>		

Name: _____

Which way does each word go? Write the word.

<p>1. → FLOWER ↙ FOR ← FEW ↓ FAHRENHEIT ↘ FRAME</p>	<p>1. → ELBOW ↙ EVE ← END ↘ EJECT ↓ ENDURANCE</p> <p>2. WEEK WE WAVE ← WOULD WEATHER</p>																																																																																																																																																																																
<table border="1" style="margin: auto; border-collapse: collapse;"> <tr><td></td><td></td><td style="text-align: center;">F</td><td></td><td></td><td></td><td></td><td></td></tr> <tr><td style="background-color: #cccccc;"></td><td></td><td></td><td style="text-align: center;">R</td><td style="background-color: #cccccc;"></td><td style="background-color: #cccccc;"></td><td style="background-color: #cccccc;"></td><td style="background-color: #cccccc;"></td></tr> <tr><td></td><td style="background-color: #cccccc;"></td><td></td><td></td><td style="text-align: center;">A</td><td style="background-color: #cccccc;"></td><td style="background-color: #cccccc;"></td><td style="background-color: #cccccc;"></td></tr> <tr><td style="background-color: #cccccc;"></td><td style="background-color: #cccccc;"></td><td></td><td></td><td></td><td style="text-align: center;">M</td><td style="background-color: #cccccc;"></td><td style="background-color: #cccccc;"></td></tr> <tr><td style="background-color: #cccccc;"></td><td style="background-color: #cccccc;"></td><td></td><td></td><td></td><td></td><td style="text-align: center;">E</td><td style="background-color: #cccccc;"></td></tr> <tr><td style="background-color: #cccccc;"></td><td style="background-color: #cccccc;"></td><td></td><td></td><td></td><td></td><td></td><td style="background-color: #cccccc;"></td></tr> <tr><td style="background-color: #cccccc;"></td><td style="background-color: #cccccc;"></td><td></td><td></td><td></td><td></td><td></td><td style="background-color: #cccccc;"></td></tr> <tr><td style="background-color: #cccccc;"></td><td style="background-color: #cccccc;"></td><td></td><td></td><td></td><td></td><td></td><td style="background-color: #cccccc;"></td></tr> <tr><td style="background-color: #cccccc;"></td><td style="background-color: #cccccc;"></td><td></td><td></td><td></td><td></td><td></td><td style="background-color: #cccccc;"></td></tr> <tr><td style="background-color: #cccccc;"></td><td style="background-color: #cccccc;"></td><td></td><td></td><td></td><td></td><td></td><td style="background-color: #cccccc;"></td></tr> <tr><td style="background-color: #cccccc;"></td><td style="background-color: #cccccc;"></td><td></td><td></td><td></td><td></td><td></td><td style="background-color: #cccccc;"></td></tr> </table>			F									R									A									M									E																																																		<table border="1" style="margin: auto; border-collapse: collapse;"> <tr><td></td><td></td><td style="text-align: center;">E</td><td style="text-align: center;">L</td><td style="text-align: center;">B</td><td style="text-align: center;">O</td><td style="text-align: center;">W</td><td></td></tr> <tr><td style="background-color: #cccccc;"></td><td></td><td></td><td></td><td style="background-color: #cccccc;"></td><td style="background-color: #cccccc;"></td><td></td><td style="background-color: #cccccc;"></td></tr> <tr><td></td><td style="background-color: #cccccc;"></td><td></td><td></td><td style="text-align: center;">E</td><td></td><td style="background-color: #cccccc;"></td><td style="background-color: #cccccc;"></td></tr> <tr><td style="background-color: #cccccc;"></td><td style="background-color: #cccccc;"></td><td></td><td></td><td style="text-align: center;">W</td><td></td><td style="background-color: #cccccc;"></td><td style="background-color: #cccccc;"></td></tr> <tr><td style="background-color: #cccccc;"></td><td style="background-color: #cccccc;"></td><td></td><td></td><td></td><td></td><td></td><td style="background-color: #cccccc;"></td></tr> <tr><td style="background-color: #cccccc;"></td><td style="background-color: #cccccc;"></td><td></td><td></td><td></td><td></td><td></td><td style="background-color: #cccccc;"></td></tr> <tr><td style="background-color: #cccccc;"></td><td style="background-color: #cccccc;"></td><td></td><td></td><td></td><td></td><td></td><td style="background-color: #cccccc;"></td></tr> <tr><td style="background-color: #cccccc;"></td><td style="background-color: #cccccc;"></td><td></td><td></td><td></td><td></td><td></td><td style="background-color: #cccccc;"></td></tr> <tr><td style="background-color: #cccccc;"></td><td style="background-color: #cccccc;"></td><td></td><td></td><td></td><td></td><td></td><td style="background-color: #cccccc;"></td></tr> <tr><td style="background-color: #cccccc;"></td><td style="background-color: #cccccc;"></td><td></td><td></td><td></td><td></td><td></td><td style="background-color: #cccccc;"></td></tr> <tr><td style="background-color: #cccccc;"></td><td style="background-color: #cccccc;"></td><td></td><td></td><td></td><td></td><td></td><td style="background-color: #cccccc;"></td></tr> </table>			E	L	B	O	W														E								W																																																											
		F																																																																																																																																																																															
			R																																																																																																																																																																														
				A																																																																																																																																																																													
					M																																																																																																																																																																												
						E																																																																																																																																																																											
		E	L	B	O	W																																																																																																																																																																											
				E																																																																																																																																																																													
				W																																																																																																																																																																													

<p>How many digits are in ten times ten? _____</p>	<p>11 kg = _____ g</p>	<p>21 ÷ 7 = _____</p>							
<table style="margin: auto;"> <tr><td style="text-align: right;">32</td></tr> <tr><td style="text-align: right;">+ 36</td></tr> <tr><td style="text-align: right;">-----</td></tr> </table>	32	+ 36	-----	<p>Circle the addition property for $67 + 58 = 58 + 67$.</p> <p>commutative property associative property</p>	<p>1 cm = 10 mm</p> <p>21 cm = _____ mm</p>	<table style="margin: auto;"> <tr><td style="text-align: right;">77</td></tr> <tr><td style="text-align: right;">- 41</td></tr> <tr><td style="text-align: right;">-----</td></tr> </table>	77	- 41	-----
32									
+ 36									

77									
- 41									

<p>$(6 + 4) + 2 =$ _____</p>	<table style="margin: auto;"> <tr><td style="text-align: right;">461</td></tr> <tr><td style="text-align: right;">+ 225</td></tr> <tr><td style="text-align: right;">-----</td></tr> </table>	461	+ 225	-----	<p>Write whether this fragment is missing a subject or a verb.</p> <p>had a lot of fun</p> <p>_____</p>				
461									
+ 225									

Name: _____

1. CREPT
COUPON
↓ CRATE
CAGE
CURLING

2. GET
GLAD
↓ GLACIER
GREASE
GATE
GO

3. BAND
↓ BITING

4. DIE
↑ DYE
DREARY
DAMP
DAY
DISH

					1				
				2					
			3	B					
				I					
				T					
				I		4			
				N		5	A		
G	O	6	L	G	S				
				K					
					L				
					I				
L	E	U	7	F	A				
				8	B				

5. ASK
↓ ARCTIC

6. ↖ LED
LUGE
LAND
LET
LOG

7. FACTORY
← FUEL
FRY
FIT

8. BIKE
BITTER
↑ BAIL

What time is 14 hours after 1:00 a.m.?

$10 \times 11 =$

$$\begin{array}{r} 473 \\ - 207 \\ \hline \end{array}$$



Holly has two favorite numbers. If you add her favorite numbers, you get 16. If you multiply her favorite numbers, you get 48. What are her mystery numbers?

Circle the smallest number:

87,396,454,176 410,295
9,803,247,091 37,685,012

$5 \times 3 =$



Name: _____

Use each of the blocks to spell five of your spelling words.

A I
 E
 I C
 B
 R I
 R
 N
 U
 T

E
 N C
 C O
 A T
 O
~~M~~ N F

L
C
G
U D
~~R~~ ~~M~~
R

G
S
U
I D
E

L O
I T
R
C
U

1.										
2.										M
3.								R	M	
4.										
5.										

Write the hidden word. Start at one letter and then move either left or right. Continue in same direction.

$$\begin{array}{r}
 461 \\
 + 378 \\
 \hline
 \end{array}$$

In the number 13,368,653, the digit 8 is in what place?

23 kg = _____ g

Name: _____



The vowels are missing in the word search.
Fill in the missing vowels and circle the words.

S P T M S T
 F T R N N H
 T N T H R
 C L L R T C C R
 N H N N Y R
 P **U** **T** **I** **L** **I** **Z** **E** L
 L T R R Y
 M X T R T R
 M L D R
 M D S P R S

LITERARY • ANNOY • DISPERSE
 MIXTURE • CREATE • RULER
 OPTIMIST • NEITHER • AFTERNOON
 LEADER • CELLAR • UTILIZE

Look at the chart.
The number 26 is in the
3rd column of the 1st row.

22	24	26	28	30
32	34	36	38	40
42	44	46	48	50
52	54	56	58	60

What number is in the
3rd column of the 3rd row?

If the pattern continues,
what number would go in the
5th column of the 5th row?

$$\begin{array}{r} 282 \\ + 495 \\ \hline \end{array}$$



Each word is missing 2 letters. Fill in the missing letters to complete each word.

t_____st

gr_____f

apprais_____

qu_____ter

_____rap

ca_____ful

ska_____

supp_____

an_____ated

f_____gile

How many pounds are in 80 ounces?

_____ pounds

12 x 3 =

$$\begin{array}{r} 2 \\ +2 \\ \hline 4 \end{array}$$

Name: _____

Fill in the missing letters. Write ph, ff, f, or gh.

e _____ ff _____ ort

o _____ er

pam _____ let

_____ ase

_____ ost

nei _____ bor

_____ etto

bene _____ it

_____ ame

lau _____

pro _____ et

hope _____ ul

di _____ erence

tro _____ y

o _____ ice

Draw one line to find two words in each puzzle. The bold letters start each word. You can move left, right, up, or down. Write the two words that you find.

V R H E I E E E
S M N G M N R V
Z G U Z D T N D
A I A T I B Q Z
Y U A O A I H X
A Q O U A I N **E**
Q L **M** N T D J B
G A F I P M A P
B P I C O E N A
E I S O O A P U

A J **S** C I F I G
D A L D **S** O R D
I T U P O P X X
E E W H F O A I
R S U T D A O B
B Y N J I H U F
A H I V R V A O
F X M M D Y B U
O C I V I I A A
A D T C A O I A

I E I Q A H N U
A D A Q Y E Y O
P O E A D F K E
C K Y A E D M H
U E V A O X J K
O O O I K L K I
S I I V E T N W
G X S E **R** R C U
M Q C **O** V E O K
O I I G S E M Z

Write the hidden word. Start at one letter and then move either left or right.

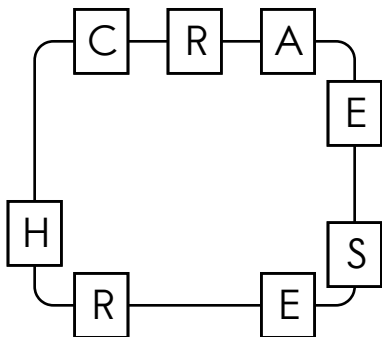

Complete the pattern.

$3,000 \times 3 =$ _____

$300 \times 3 =$ _____

$30 \times 3 =$ _____

$3 \times 3 =$ _____