



Teacher Word Study

Week of _____



My Name: _____

Your Words

Pick 1 to do:

- page 1
- pages 2-3

Spelling Break

Pick 1 to do:

- page 12
- page 13

Spelling Workout

Pick 7 to do:

- page 4
- page 5
- page 6
- page 7
- page 8
- page 9
- page 10
- page 11



Name: _____

edHelper

Picture Dictionary

Draw a picture of 11 of your words. Write the word in cursive.



EXAMPLE. laughed

1. _____

2. _____

3. _____

4. _____

5. _____

Name: _____

edHelper

6. _____

7. _____

8. _____

9. _____

10. _____

11. _____

Name: _____

Teachers' Day Word Study
Fourth Grade

custodian c c u u t u x c u s t o d i a n e z d o

ruler r r r u l r u l m u s h p f r r u l e r

conclusion c u i q l b s p o c o n c l u s i o n o

world d y d w o r l d d w o r l c o s o l w b

skills l s k i l s i r l s l u s k i l l s s l

planner i o k e p l a n u r a p l a n n e r r u

investigate e t i n v e s t i g a t e i t i g t e s

pencil l b e g p e n c u l n r h m p e n c i l

science c l z i s c i e n c e c h s c a a n c e

recess r e c e s s e s d g e c a s r r e e s s

multiplication t n l t m u l t i p l i c a t i o n i i

whiteboard d e w h i t e b o a r d h r r y b k o e

respect r e s p e c t p e c r e p e c t s s e c

professional y p r o f e s s i o n a l k f i e o j o

topic p t e z o h p t o p i c o t w t o p c q

learning o e l e a r n i n g n r i l e a r i n g

language l a n g u a g e a l n w l a n u a g e g

scissors s i s s o r s s c i s s o r s x s g s s

history x h y s y h i s t o r y h i s t o y n h

grateful g r a t e f u l l g r a t e f u l z l d

board e o a q b l b u o r d g d b o a r d a o

initiative a t i l i a i n i t i a t i v e t v n i

listening x l i s t e n i n g i l i s t e n i g u

Name: _____

The vowels are missing in the word search.
Fill in the missing vowels and circle the words.

F L D T R P
 S L N W R L D N
 S C S S R S
 C S C N C L
 N Q H S T R Y L
 R L R B R D
 N T T V
C O N C L U S I O N
 P R P N C L G R
 C L S S T P C

CONCLUSION • RULER • CLASS
 HISTORY • SCISSORS • FIELDTRIP
 BOARD • PENCIL • SCIENCE
 WORLD • TOPIC • INITIATIVE

C O N C L U S I O N H L I N N
 I C L B O A R D D L V A R T I
 R S R P L A N N E R E L U R N
 E I R S C I S S O R S I I Q E
 T O P I C D R A O B E T I H W
 E V I T A I T I N I P W Y L T
 S K I L L S Y R O T S I H I C
 O S I N V E S T I G A T E R E
 P C G P E N C I L N T T L L P
 L R E C E S S N E C N E I C S
 R A W O R L D N D C L A S S E
 M U L T I P L I C A T I O N R
 B G P T C A F I E L D T R I P

PLANNER • BOARD • HISTORY
 WHITEBOARD • MULTIPLICATION
 RULER • SKILLS • FIELDTRIP
 SCISSORS • INITIATIVE • SCIENCE
 PENCIL • CONCLUSION • TOPIC
 WORLD • INVESTIGATE • CLASS
 RECESS • RESPECT

Write the length in centimeters.

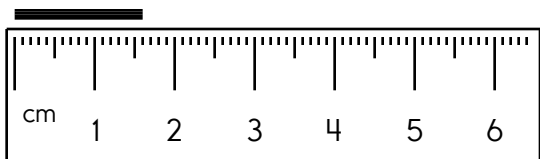

$$\begin{array}{r} 94 \\ + 72 \\ \hline \end{array}$$

$$\begin{array}{r} 46 \\ + 91 \\ \hline \end{array}$$

$$\begin{array}{r} 29 \\ + 68 \\ \hline \end{array}$$

What is a good estimate for 591 times 8?

Write 176 in expanded notation.

$$5 \overline{)15}$$

Name: _____

SCISSORS • FIELD TRIP • TOPIC • RECESS • SKILLS • RULER
 LEARNING • GRATEFUL • LISTENING

Write each word into the puzzle.

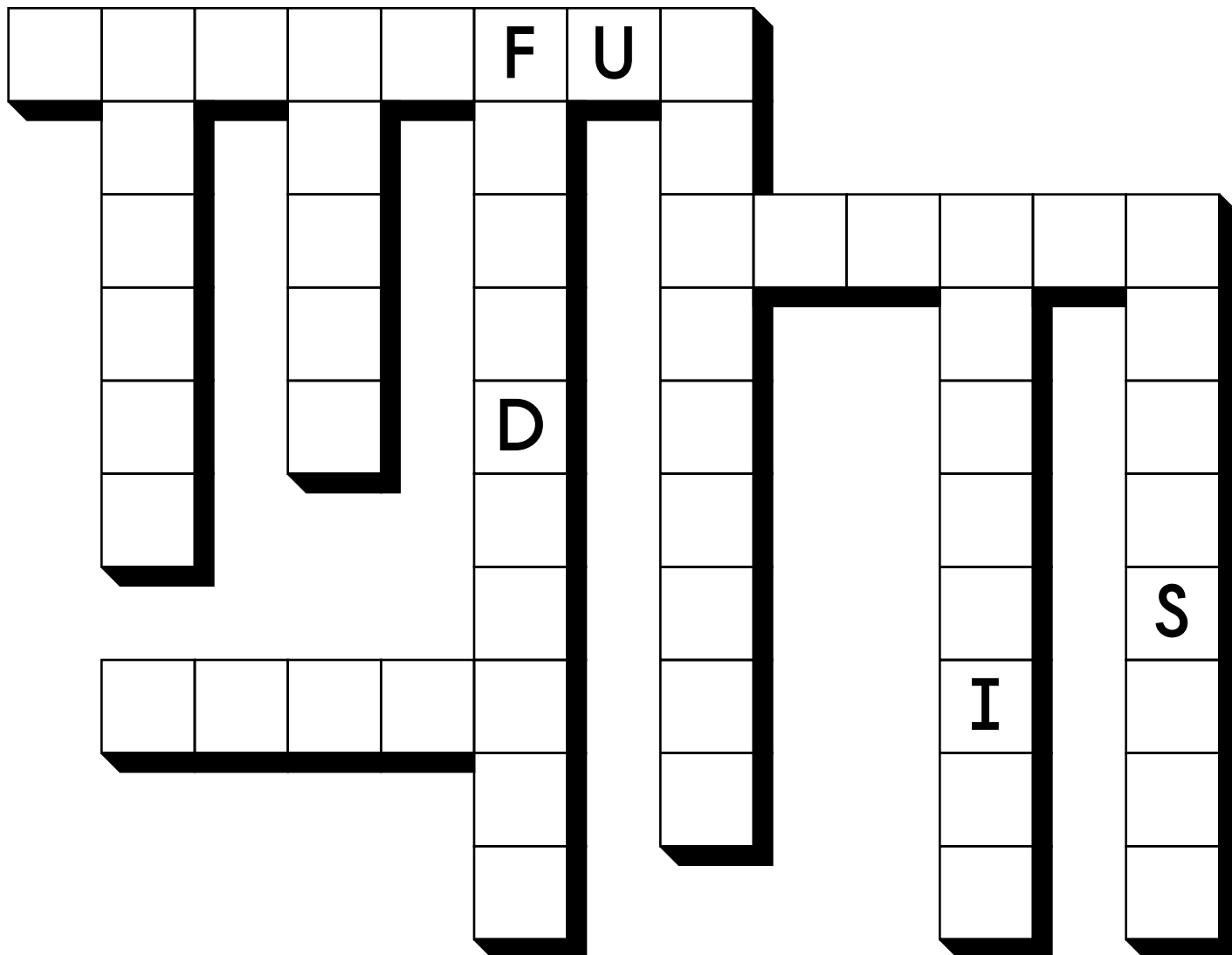

Write an even number with a
four in the tens place.



Name: _____

Circle words to the RIGHT or DOWN. Every letter is used exactly ONCE.

C L I D S G P H C U S T O D I A N
 O R A N O C R L I B T L E A R N I N G
 M E N R P I A A S O O G E T R U L E R
 E S G E E S T N T A P S K I L L S W
 R P U C N S E N O R I M Y C L A S S O
 O E A E C O F E R D C S C I E N C E R
 P C G S I R U R Y L I S T E N I N G L

Write the words found: E T E S L S L I N V E S T I G A T E D

WORLD	RULER	
_____	_____	_____
_____	_____	_____
_____	_____	_____
_____	_____	_____
_____	_____	_____
_____	_____	_____
_____	_____	_____
_____	_____	_____

<p>If $\square = 10$, then $17 - \square =$ _____</p>	<p>What is half of 42? _____</p>	$\begin{array}{r} 71 \\ 29 \\ + 25 \\ \hline \end{array}$
---	---	---

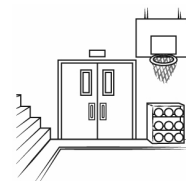

$\begin{array}{r} 64 \\ - 15 \\ \hline \end{array}$	$\begin{array}{r} 52 \\ - 29 \\ \hline \end{array}$	$\begin{array}{r} 89 \\ - 54 \\ \hline \end{array}$	$\begin{array}{r} 77 \\ - 62 \\ \hline \end{array}$	$\begin{array}{r} 93 \\ + 59 \\ \hline \end{array}$
---	---	---	---	---



<p>$21 + 2 =$ _____</p>	<p>What is 10 tens equal to? _____</p>
------------------------------------	---

Name: _____

Circle the words.

field trip respect professional conclusion listening history
 respect conclusion whiteboard learning history history
 respect listening whiteboard learning history field trip

Write the hidden word. Start at one letter and then move either left or right. Continue in same direction.

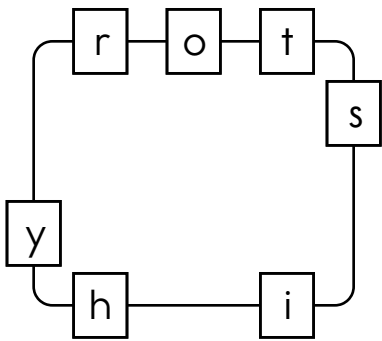

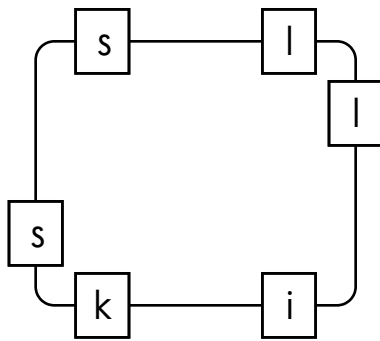

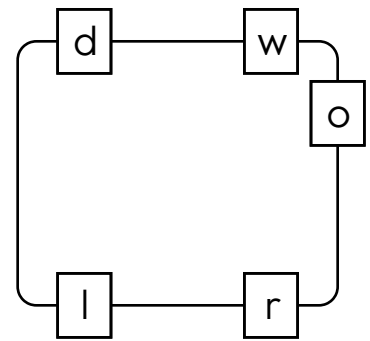

Draw one line to find two words in each puzzle. The bold letters start each word. You can move left, right, up, or down. Write the two words that you find.

Z T R U E I C X
 C A I O O E X Q
 A I C N E J Y O
 U L **S** E **P** P D C
 W X K L S I A W
 E Z I L I J U L
 C U F V B I P U
 E O D E Z G T V

M V J Z V E C E
 R O P I S **R** S S
 P D U L W O **B** G
 O G U O B A I A
 S T A U I R D I
 P K I C S R Z B
 Q I R Y Z R E U
 L I U L A O A E

C D S N D I C P
 J L Q U U J K L
 O R D Z M E Z B
W O O O W W D X
 C H B C S C U U
 I E A I V P J E
 P F Q F A U E V
 O **T** P T A A A E

Name: _____

Use each of the blocks to spell four words.

L S
 L
 C
 I C
 O
 R
L A

P
 D
 K
 T
I L
 S S
 W O
S

1.					
2.		K			
3.	W	O			
4.					

Try to spell some words.

ss • ica • sk • mul • pl • ~~ic~~ • cil • en • pen • ce • ti
~~top~~ • al • on • fe • ion • pro • sci • ls • il • ti

topic _____

Circle the words.

field trip scissors learning topic planner pencil board skills

planners scissors board planner learning learning topic

planner grateful learning topic learning pencil pencils skills

Name: _____

Which way does each word go? Write the word.

<p>1. ↘ SQUIRT ↓ SOLSTICE → SOUGHT ← SAD</p> <table border="1" style="width: 100%; height: 100%; border-collapse: collapse; text-align: center;"> <tr><td></td><td></td><td>1</td><td>S</td><td></td><td></td><td></td><td></td></tr> <tr><td style="background-color: #cccccc;"></td><td style="background-color: #cccccc;"></td><td></td><td>O</td><td></td><td style="background-color: #cccccc;"></td><td style="background-color: #cccccc;"></td><td style="background-color: #cccccc;"></td></tr> <tr><td style="background-color: #cccccc;"></td><td style="background-color: #cccccc;"></td><td></td><td>L</td><td></td><td style="background-color: #cccccc;"></td><td style="background-color: #cccccc;"></td><td style="background-color: #cccccc;"></td></tr> <tr><td style="background-color: #cccccc;"></td><td style="background-color: #cccccc;"></td><td></td><td>S</td><td></td><td style="background-color: #cccccc;"></td><td style="background-color: #cccccc;"></td><td style="background-color: #cccccc;"></td></tr> <tr><td style="background-color: #cccccc;"></td><td style="background-color: #cccccc;"></td><td></td><td>T</td><td></td><td style="background-color: #cccccc;"></td><td style="background-color: #cccccc;"></td><td style="background-color: #cccccc;"></td></tr> <tr><td style="background-color: #cccccc;"></td><td style="background-color: #cccccc;"></td><td></td><td>I</td><td></td><td style="background-color: #cccccc;"></td><td style="background-color: #cccccc;"></td><td style="background-color: #cccccc;"></td></tr> <tr><td style="background-color: #cccccc;"></td><td style="background-color: #cccccc;"></td><td></td><td>C</td><td></td><td style="background-color: #cccccc;"></td><td style="background-color: #cccccc;"></td><td style="background-color: #cccccc;"></td></tr> <tr><td style="background-color: #cccccc;"></td><td style="background-color: #cccccc;"></td><td></td><td>E</td><td></td><td style="background-color: #cccccc;"></td><td style="background-color: #cccccc;"></td><td style="background-color: #cccccc;"></td></tr> </table>			1	S								O								L								S								T								I								C								E					<p>1. ↓ WEATHER → WEED ← WAIT</p> <p>2. BERRY ↓ BLIZZARD BUSH BATCH</p> <table border="1" style="width: 100%; height: 100%; border-collapse: collapse; text-align: center;"> <tr><td style="background-color: #cccccc;"></td><td style="background-color: #cccccc;"></td><td></td><td></td><td>1</td><td></td><td></td><td></td></tr> <tr><td style="background-color: #cccccc;"></td><td style="background-color: #cccccc;"></td><td></td><td>2</td><td>B</td><td>E</td><td>R</td><td>R</td><td>Y</td></tr> <tr><td style="background-color: #cccccc;"></td><td style="background-color: #cccccc;"></td><td style="background-color: #cccccc;"></td><td style="background-color: #cccccc;"></td><td></td><td></td><td style="background-color: #cccccc;"></td><td style="background-color: #cccccc;"></td><td style="background-color: #cccccc;"></td></tr> <tr><td style="background-color: #cccccc;"></td><td style="background-color: #cccccc;"></td><td style="background-color: #cccccc;"></td><td style="background-color: #cccccc;"></td><td></td><td></td><td style="background-color: #cccccc;"></td><td style="background-color: #cccccc;"></td><td style="background-color: #cccccc;"></td></tr> <tr><td style="background-color: #cccccc;"></td><td style="background-color: #cccccc;"></td><td style="background-color: #cccccc;"></td><td style="background-color: #cccccc;"></td><td></td><td></td><td style="background-color: #cccccc;"></td><td style="background-color: #cccccc;"></td><td style="background-color: #cccccc;"></td></tr> <tr><td style="background-color: #cccccc;"></td><td style="background-color: #cccccc;"></td><td style="background-color: #cccccc;"></td><td style="background-color: #cccccc;"></td><td></td><td></td><td style="background-color: #cccccc;"></td><td style="background-color: #cccccc;"></td><td style="background-color: #cccccc;"></td></tr> <tr><td style="background-color: #cccccc;"></td><td style="background-color: #cccccc;"></td><td style="background-color: #cccccc;"></td><td style="background-color: #cccccc;"></td><td></td><td></td><td style="background-color: #cccccc;"></td><td style="background-color: #cccccc;"></td><td style="background-color: #cccccc;"></td></tr> <tr><td style="background-color: #cccccc;"></td><td style="background-color: #cccccc;"></td><td style="background-color: #cccccc;"></td><td style="background-color: #cccccc;"></td><td></td><td></td><td style="background-color: #cccccc;"></td><td style="background-color: #cccccc;"></td><td style="background-color: #cccccc;"></td></tr> <tr><td style="background-color: #cccccc;"></td><td style="background-color: #cccccc;"></td><td style="background-color: #cccccc;"></td><td style="background-color: #cccccc;"></td><td></td><td></td><td style="background-color: #cccccc;"></td><td style="background-color: #cccccc;"></td><td style="background-color: #cccccc;"></td></tr> </table>					1							2	B	E	R	R	Y																																																															
		1	S																																																																																																																																														
			O																																																																																																																																														
			L																																																																																																																																														
			S																																																																																																																																														
			T																																																																																																																																														
			I																																																																																																																																														
			C																																																																																																																																														
			E																																																																																																																																														
				1																																																																																																																																													
			2	B	E	R	R	Y																																																																																																																																									

If you add 8 to me, the sum is 68. What number am I?

$32 + 8 = \underline{\hspace{2cm}}$

Calculate the product of 4 and 12.

Write the number for one thousand, nine hundred six.

What fraction of the box is shaded?

3

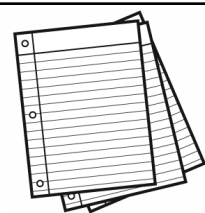
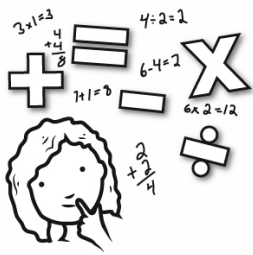

Round 239,185 to the nearest thousand.

List the first four multiples of 10.

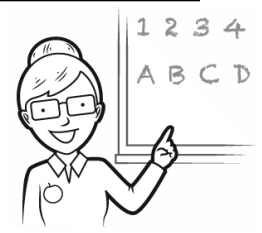

Name: _____

1. → BITING
BITTER
BREAD
BULL
BOAST

2. AN
AT
↙ ART
ATTEND
ARCTIC

3. ↓ FAHRENHEIT
FELT
FAT
FARM
FACT
FOR

4. ↙ EACH
ENDURANCE
5. → CAR
COW
CAN
CELSIUS
CUP

				¹ B					
/	/			I		/	/	/	/
/	/		²	T				/	/
/				T		³ F			
/		/		E	O			/	/
/		/		R	⁴ E				
/				A					
/				C			⁵		
/		H						/	/
/	T	F	E	⁶ L				/	/
/	/	/	/					/	/
/	/	/	/	/				/	/
/	/	/	/	/	/	/		/	/
			⁷						/

6. LEFT
LOT
LUMP
↓ LUGE
LIVE
7. FOX
FED
FOG
→ FURNACE

$$\begin{array}{r} 92 \\ + 29 \\ \hline \end{array}$$

Add one hundred to 478.

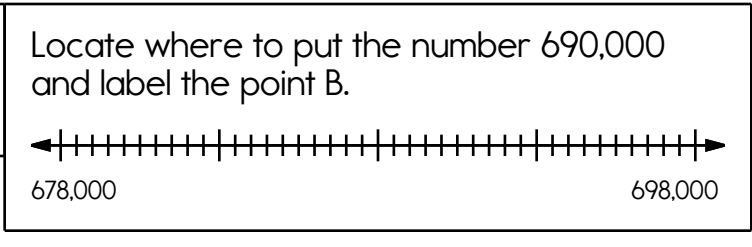

What are the first three multiples of 9?

Write a fraction to represent what is shaded.



Name: _____

Write a short story. Use as many of these words as you can.
Circle each word in the word box that appears in your story.

compliment • gauze • aunts • fun • sore • agree • origin • thirty subscribe • signaled • lifeless • rude • skill • hotel • demonstrate ditches • come • flea • weakness • anxiously • morning • principal chili • year • guideline

Which of the following is a complete sentence?

- | | |
|----------------|-------------------------|
| (A) I lied | (B) delicious soup |
| (C) not hungry | (D) Sylvie thoughtfully |

Color in $\frac{1}{2}$ of the rectangle.

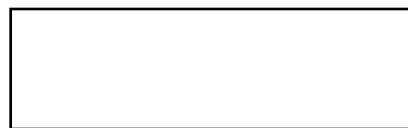

Name: _____

Each word is missing 2 letters. Fill in the missing letters to complete each word.

co _____ d

frag _____ e

pea _____

cho _____

scisso _____

rul _____

fo _____ unate

_____ ast

COUS _____

i _____ hes

Justin bought some special food for his cows. Justin has seven cows. If he bought three pounds of food for each cow, how many pounds of food did he buy in all?

Use each of the letters to fill in the grid. Write two words.

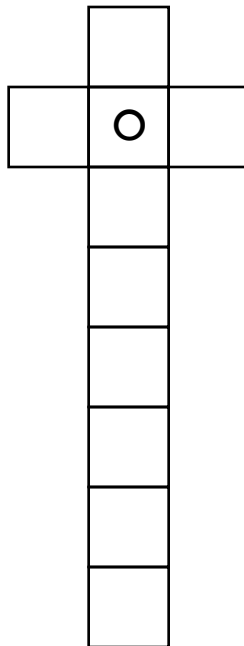

Eric picked three quarts of blueberries. Some of the blueberries are ripe and some are not ripe. If he takes one blueberry from the basket without looking, what are the possible outcomes?

[R]

[M]

[O] [N]

[O] [W]

[R]

[W]

[T]

Write the numeral for eight hundred forty-eight.

Is 13 smaller than 31?

$$\begin{array}{r} 2 \\ +2 \\ \hline 4 \end{array}$$