

Teacher Spelling

Week of _____



$$\begin{array}{r} 2 \\ +2 \\ \hline 4 \end{array}$$



My Name: _____

Your Words

Pick 1 to do:

- page 1
- pages 2-3

Spelling Break

Pick 1 to do:

- page 11
- page 12

Spelling Workout

Pick 6 to do:

- page 4
- page 5
- page 6
- page 7
- page 8
- page 9
- page 10



Name: _____

Picture Dictionary

Draw a picture of 11 of your words. Write the word.



EXAMPLE. laughed _____

1. _____

2. _____

3. _____

4. _____

5. _____

Name: _____

edHelper

6. _____

7. _____

8. _____

9. _____

10. _____

11. _____

Name: _____

The first letter is ...

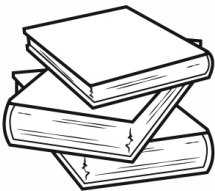

ooks



all



aper



ubtraction



esks

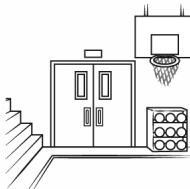

ym



ibrary



pell

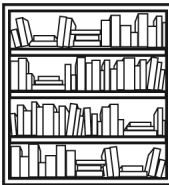

ookshelf



nite

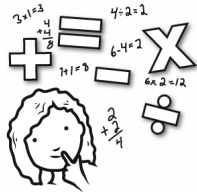

ath



eacher

Name: _____

The first letter is ...

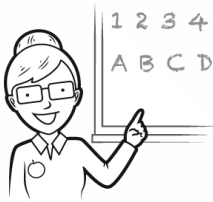

1 2 3 4
A B C D

each



ue



rt

The last letter is ...



4
-2
—
2

subtrac



student



writ

The missing vowel is ...



mayb

sp



bo ks

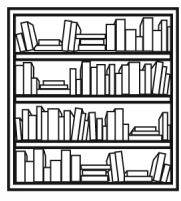

bo kshelf

Name: _____

d a o t y c n r h o p r
 n s i f s n n a w d r p
 m r w o t d m d o s o e
 u w b p a t i d r a j n
 s r i r f t b i k u e c
 i i n r f e a t s i c i
 c t d i j s d i h p t l
 a e e u e o r o o g s u
 a d r l i t s n p y o c
 d s t a r t o v p m o f



write ↓



pencil ↓

binder
 projects
 addition
 staff

workshop
 music
 art
 gym

Name: _____

Circle words to the RIGHT or DOWN. Every letter is used exactly ONCE.

T U F O L D E R L A R T G Y M P
 O P R E C E S S E L E S S O N R
 F A V O R I T E A B G R E E T O
 A D D I T I O N R I D S M W J
 R E C O U N T N N R R T U R E
 W O R K S H O P I D E I A S I C
 S C I S S O R S N E A D F I T T
 S E Q U E N C E G R M E F C E S

Write the words found:

<u>PROJECTS</u>	<u>WRITE</u>	_____
_____	_____	_____
_____	_____	_____
_____	_____	_____
_____	_____	_____
_____	_____	_____
_____	_____	_____

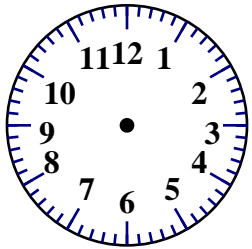
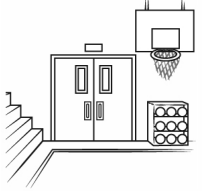
$\begin{array}{r} 38 \\ + 21 \\ \hline \end{array}$	$\begin{array}{r} 23 \\ + 52 \\ \hline \end{array}$	$\begin{array}{r} 30 \\ + 35 \\ \hline \end{array}$	$\begin{array}{r} 51 \\ + 35 \\ \hline \end{array}$	 <p>10 : 15</p>	$\begin{array}{r} 1 \\ 7 \\ + 1 \\ \hline \end{array}$
seventeen <input type="radio"/> 19 <input type="radio"/> 16 <input type="radio"/> 17	$1 \text{ ____ } 1$ <input type="radio"/> < <input type="radio"/> = <input type="radio"/> >			1 penny 1 dime <input type="radio"/> 5¢ <input type="radio"/> 10¢ <input type="radio"/> 11¢	
What month comes before November? _____	$14 + 4 = \text{ ______ }$			$\begin{array}{r} 86 \\ - 65 \\ \hline \end{array}$	

Name: _____

Try to spell some words.

~~xi~~ • ite • oa • ~~reg~~ • ~~you~~ • vor • n b • fa • rd • er • eti
 nd • mus • bi • sti • bu • ons • que • ll • ic • ~~ng~~

regrouping _____

Write the words into the boxes.

pencil • art • binder • scissors • learning • workshop • staff • gym

Circle the words.

recountbinderpredictionspencilbookshelvesscissors
 pencilrecountpredictionsscissorsbinderbookshelves
 predictionsbookshelvesadditionrecountpredictions

1 dime 1 nickel

- 40¢
- 16¢
- 15¢

Which number has a 5
 in the ones place?

- 576
- 756
- 765

5 tens and 2 ones

- 52
- 25
- 2

Name: _____

Circle the words.

greetbookshelvesbinderlessonadditionwriterecessart
 greetwriteadditionwriterecessquestionsartsequence
 additionwriteartadditionbinderrecesssequence

Write the words into the boxes.

binder • write • learning • favorite • art • pencil • workshop

<input type="text"/>	<input type="text"/>	<input type="text"/>	<input type="text"/>	<input type="text"/>	<input type="text"/>	<input type="text"/>	<input type="text"/>	<input type="text"/>	<input type="text"/>	<input type="text"/>	<input type="text"/>	<input type="text"/>	<input type="text"/>			
<input type="text"/>	<input type="text"/>	<input type="text"/>	<input type="text"/>	<input type="text"/>	<input type="text"/>	<input type="text"/>	<input type="text"/>	<input type="text"/>	<input type="text"/>	<input type="text"/>	<input type="text"/>	<input type="text"/>	<input type="text"/>			
<input type="text"/>	<input type="text"/>	<input type="text"/>	<input type="text"/>	<input type="text"/>	<input type="text"/>	<input type="text"/>	<input type="text"/>	<input type="text"/>	<input type="text"/>	<input type="text"/>	<input type="text"/>	<input type="text"/>	<input type="text"/>	<input type="text"/>	<input type="text"/>	<input type="text"/>

Try to spell some words.

el • bul • sci • ard • ~~ou~~ • ~~re~~ • le • ct • tin • ss • ~~rt~~
 ors • pre • ns • di • ss • ksh • ce • io • ves • re • bo
 boo

recount _____



Subtract 1 or 10.



<input type="text"/>	95	<input type="text"/>	29	<input type="text"/>	<input type="text"/>	<input type="text"/>	33
				82	65		

Name: _____

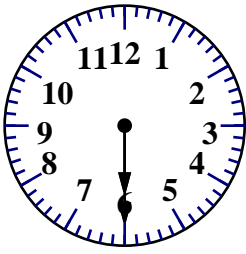
Which way does each word go? Write the word.

<p>1. ↓ DRENCHED ← DOLLAR → DOG</p>	<p>1. ↓ MIGRATE → MEN ← MYSELF</p> <p>2. → FIND FLEECE FOUND</p>
<p>R A L L O D</p>	<p>D N U O F</p>

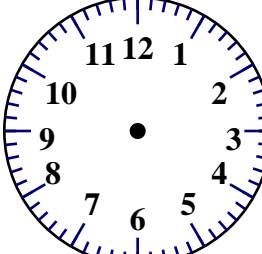
<p>Count by fours.</p> <p>4 _____ 16 20 24</p>	 <p>_____ : _____</p>	<p>ten less than 565</p>	
			

<p>Circle the number that is less. 972 968</p>	<p>03:00</p>		<p>ten less than 817</p>
			

<p>21 - 9 = _____</p> <p><input type="radio"/> 12 <input type="radio"/> 12 <input type="radio"/> 19</p>	<p>3 nickels 1 dime</p> <p><input type="radio"/> 24¢ <input type="radio"/> 35¢ <input type="radio"/> 25¢</p>	<p>Which number has a 9 in the hundreds place?</p> <p><input type="radio"/> 397 <input type="radio"/> 379 <input type="radio"/> 937</p>
---	--	---

Name: _____

Use these numbers to fill in the blanks.

33 19 23 25 21

The smallest number is _____.

The largest number is _____.

2 more than 23 is _____.

_____ is less than 25 but more than 19.

Write **dr** or **tr** to complete each word.

_____ ay _____ op

_____ eat _____ um

$$\begin{array}{r} 44 \\ + 55 \\ \hline \end{array}$$

When you take six away from me, the answer is three. What number am I?

Write the hidden word. Start at one letter and then move either left or right.

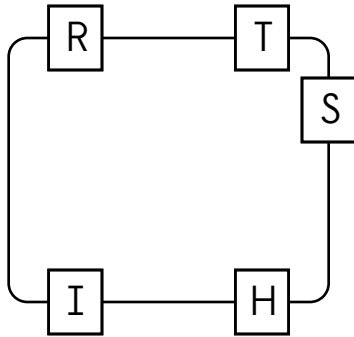

b n b g w o n l r o
 e n g o g o n l e v
 l s n g s e m o a a
 o o b g o o l n l n
 n n g n n p l g o s
 g b l l g o j s n n
 o w r o n g m g g b
 g o g o w n n l n s

How many **-ONG** words can you find in the word search? Write the words you find.

long

$$\begin{array}{r} 30 \\ + 43 \\ \hline \end{array}$$

$$\begin{array}{r} 44 \\ + 54 \\ \hline \end{array}$$



Circle the even number.

9 1 11 16
17 15

1 penny 1 dime

11¢ 10¢ 12¢



Name: _____

Fix the sentence.

i am eight years old

Write the hidden word. Start at one letter and then move either left or right. Continue in same direction.

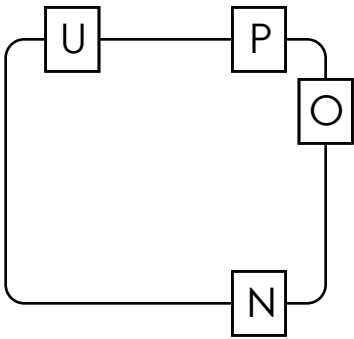

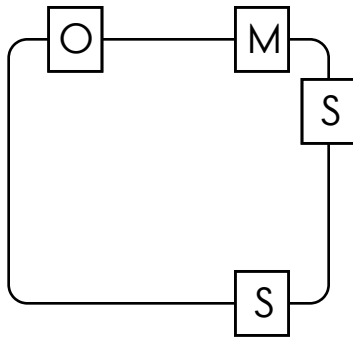

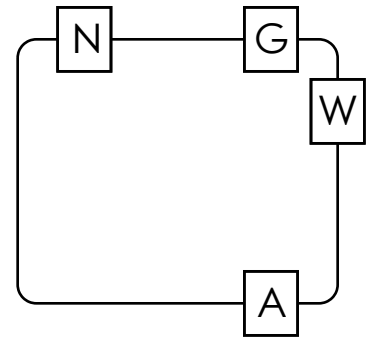

Write the final part of the math analogy.

seven dimes and seven pennies : \$0.77 :: six dimes and seven pennies :

Explain why you think your answer is correct.

04:00

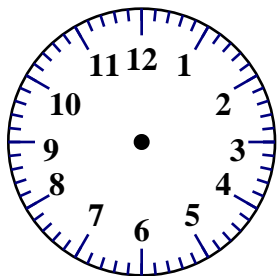

twenty-two

$$\begin{array}{r} 95 \\ - 72 \\ \hline \end{array}$$

$$\begin{array}{r} 33 \\ - 12 \\ \hline \end{array}$$

$$50 + 4 = \underline{\hspace{2cm}}$$

